

A Forrester Total Economic Impact™ Study Prepared For Cisco Systems

The Total Economic Impact™ Of The Cisco Unified Computing System

Project Director: Sadaf R. Bellord

August 2011

FORRESTER

Headquarters | Forrester Research, Inc.
400 Technology Square, Cambridge, MA 02139 USA
Tel: +1 617.613.6000 | Fax: +1 617.613.5000 | www.forrester.com

Forrester Consulting
Making Leaders Successful Every Day

TABLE OF CONTENTS

Executive Summary.....	2
Cisco UCS Reduces IT Administrative and Hardware Costs.....	2
Factors Affecting Benefits And Costs.....	5
Disclosures.....	5
TEI Framework And Methodology.....	7
Analysis.....	8
Interview Highlights.....	8
Costs.....	10
Benefits.....	16
Flexibility.....	23
Risk.....	23
Financial Summary.....	24
Cisco Unified Computing System: Overview.....	25
Appendix A: Composite Organization Description.....	27
Appendix B: Total Economic Impact™ Overview.....	27
Appendix C: Glossary.....	28
Appendix D: Endnotes.....	30

© 2011, Forrester Research, Inc. All rights reserved. Unauthorized reproduction is strictly prohibited. Information is based on best available resources. Opinions reflect judgment at the time and are subject to change. Forrester®, Technographics®, Forrester Wave, RoleView, TechRadar, and Total Economic Impact are trademarks of Forrester Research, Inc. All other trademarks are the property of their respective companies. For additional information, go to www.forrester.com.

About Forrester Consulting

Forrester Consulting provides independent and objective research-based consulting to help leaders succeed in their organizations. Ranging in scope from a short strategy session to custom projects, Forrester's Consulting services connect you directly with research analysts who apply expert insight to your specific business challenges. For more information, visit www.forrester.com/consulting.

Executive Summary

In March 2011, Cisco Systems commissioned Forrester Consulting to examine the total economic impact and potential return on investment (ROI) enterprises may realize by deploying Cisco Unified Computing System (UCS). The purpose of this study is to provide readers with a framework to evaluate the potential financial impact of Cisco UCS on their organizations.

Cisco UCS Reduces IT Administrative and Hardware Costs

Our interviews with five existing customers and subsequent financial analysis found that a composite organization based on the organizations we interviewed experienced the risk-adjusted ROI, costs, and benefits shown in Table 1. See Appendix A for a description of the composite organization. All values have been rounded.

Forrester interviewed five existing Cisco UCS customers, completed financial analysis on these customers and modeled a representative composite organization based these interviews. The composite organization experienced the risk-adjusted ROI, costs, and benefits shown in Table 1. See Appendix A for a description of the composite organization. All values have been rounded.

Table 1

Composite Organization Three-Year Risk-Adjusted ROI¹

ROI	Payback period	Total benefits (PV)	Total costs (PV)	Net present value (NPV)
177%	4 months	\$1,345,029	(\$485,385)	\$859,644

Source: Forrester Research, Inc.

- **Benefits.** The organizations interviewed experienced the following benefits (see figure 1):
 - **Reduction in ongoing administrative effort.** (Total benefit equates a \$307,076 reduction on a total administrative cost of \$614,000). This represents the time and effort reduced when managing the data center. Organizations can maximize their IT resources and eliminate mundane tasks.
 - **Network port and switch cost reduction.** (Total benefit equates to \$703,462). This represents the reduction of 400 IP and 400 FC ports required to connect into the data center using UCS. UCS simplified structure reduces time and effort as well as capital expenditure. This category primarily measures the capital expenditure reduction.
 - **Refresh cost avoidance.** (Total benefit equates to \$185,663). This represents the hardware refreshes cost that was avoided.

- **Power and cooling cost savings.** (Total benefit equates to \$38,994, a 30% savings on a total cost of \$129,980). This represents the difference in power and cooling costs between the new UCS environment and the prior traditional server and networking architect.
- **The reduction in electrical circuits deployed.** (Total benefit equates \$42,764). This represents the reduction in power outlets necessary for the new UCS hardware versus the outlets required to support the original environment and growth.
- **Data center space cost savings.** (Total benefit equates \$38,994, presenting an annual savings of \$16,000). This represents the reduction in data center space after implementing UCS.
- **End user productivity savings.** (Total benefit equates \$28,076). This represents an improvement in end user productivity when organizations reduced the number of planned and unplanned downtimes.
- **Costs.** The organizations we interviewed experienced the following costs (see figure 2):
 - **UCS hardware, license, and annual maintenance fees.** This cost represents the investment in UCS hardware license fee and the annual maintenance cost.
 - **UCS port and switch costs.** This cost represents the investment in switches and ports required to run UCS.
 - **Implementation costs.** This category represents the IT staff time allocated to discovery, testing, and deployment of Cisco UCS.
 - **Training costs.** This cost represents the fee paid to attend third-party training course for UCS.
 - **Training opportunity costs.** This section represents the IT staff time allocated to attend UCS training course.
 - **Professional services fees.** This cost represents the investment for a member of the Cisco professional services team to be on-site during initial implementation of UCS.

Figure 1

Composite Organization Three-Year Total Benefits Breakdown Risk-Adjusted Analysis

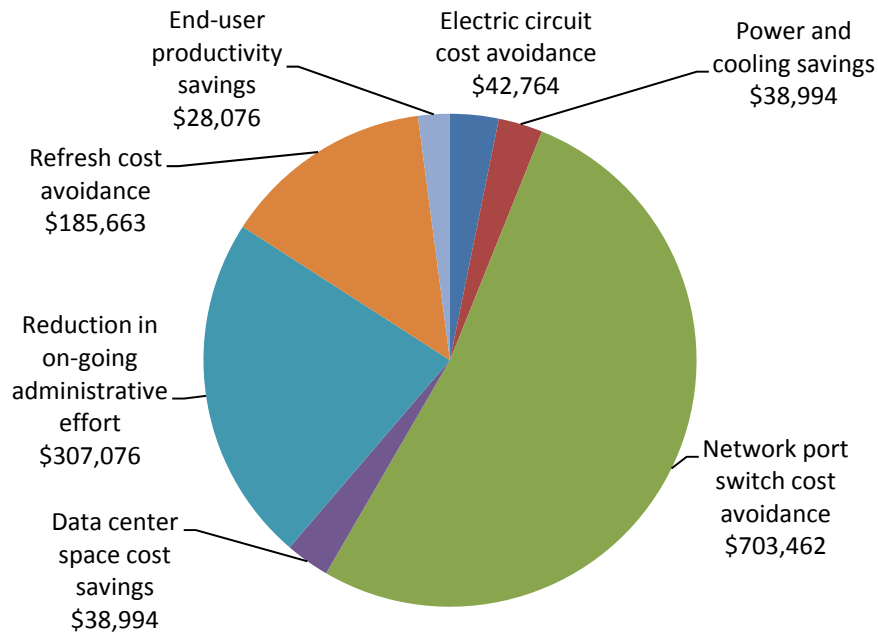

Source: Forrester Research, Inc.

Figure 2

Composite Organization Three-Year Total Costs Breakdown Risk-Adjusted Analysis

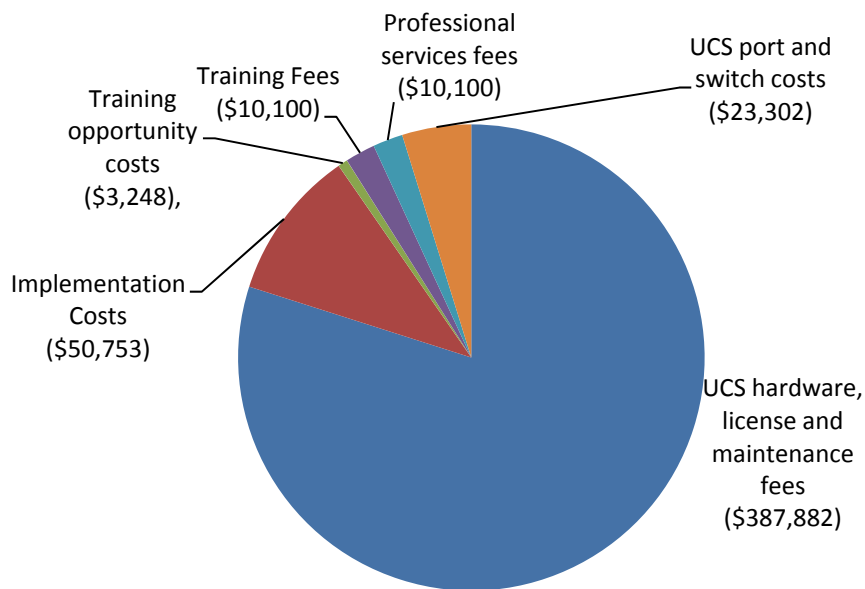

Source: Forrester Research, Inc.

Figure 3

Composite Organization Three-Year Risk-Adjusted Analysis

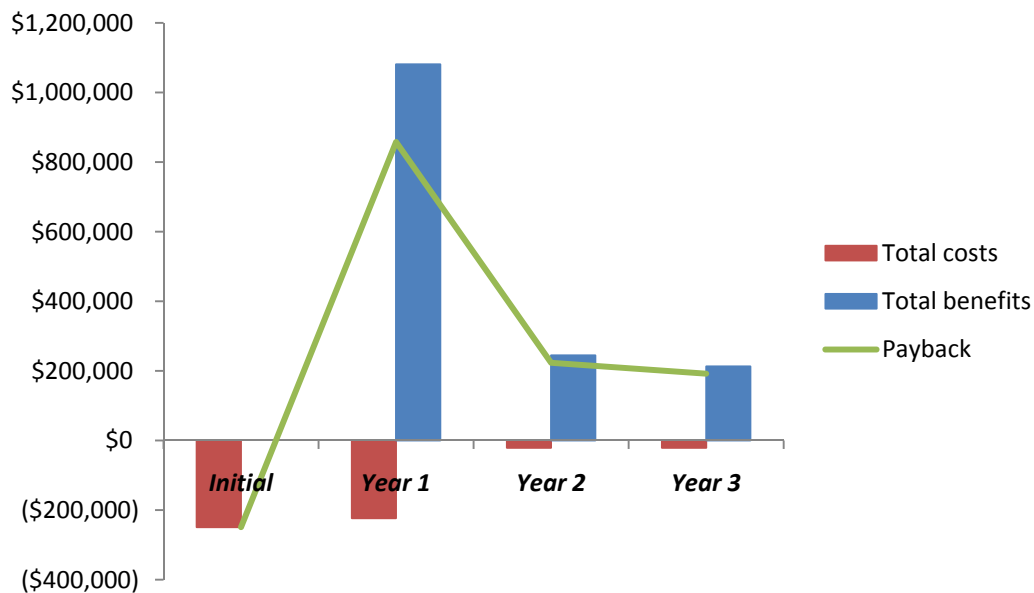

Source: Forrester Research, Inc.

Factors Affecting Benefits And Costs

Table 1 illustrates the risk-adjusted financial results that were achieved by the composite organization. The risk-adjusted values take into account any potential uncertainty or variance that exists in estimating the costs and benefits, which produces more conservative estimates. The following factors may affect the financial results that an organization may experience:

- Improvement in IT administrative effort when installing and managing hardware. The simplified environment reduced the number of mundane and repeatable tasks that could cause unnecessary user errors. Those using the advanced technology features of UCS to more fully streamline their internal processes will experience commensurately larger gains. Conversely, those that choose to rigidly adhere to former processes may experience lower benefits.
- The ability to avoid the investment in additional switches and ports necessary to connect into the data center.
- Improvement in end user productivity that may result from reduction in planned and unplanned downtime as the IT organization uses hardware and solutions that simplified its environment. Business benefits from avoidance of unplanned downtime are typically difficult to accurately model.

Disclosures

The reader should be aware of the following:

- The study is commissioned by Cisco and delivered by the Forrester Consulting group.
- Forrester makes no assumptions as to the potential ROI that other organizations will receive. Forrester strongly advises that readers should use their own estimates within the framework provided in the report to determine the appropriateness of an investment in Cisco UCS.
- Cisco reviewed and provided feedback to Forrester, but Forrester maintains editorial control over the study and its findings and does not accept changes to the study that contradict Forrester's findings or obscure the meaning of the study.
- The customer names for the interviews were provided by Cisco. Forrester conducted independent interviews with no Cisco presence and Cisco did not edit any of the customer comments, input or results.

TEI Framework And Methodology

Introduction

From the information provided in the interviews, Forrester has constructed a Total Economic Impact™ (TEI) framework for those organizations considering implementing Cisco UCS. The objective of the framework is to identify the cost, benefit, flexibility, and risk factors that affect the investment decision.

Approach and Methodology

Forrester took a multistep approach to evaluate the impact that Cisco UCS can have on an organization (see Figure 2). Specifically, we:

- Interviewed Cisco marketing, sales, consulting personnel and Forrester analysts to gather data relative to Cisco and the marketplace for UCS.
- Interviewed five organizations currently using Cisco UCS to obtain data with respect to costs, benefits, and risks.
- Designed a composite organization based on characteristics of the interviewed organizations (see Appendix A).
- Constructed a financial model representative of the interviews using the TEI methodology. The financial model is populated with the cost and benefit data obtained from the interviews as applied to the composite organization.

Figure 2

TEI Approach



Source: Forrester Research, Inc.

Forrester employed four fundamental elements of TEI in modeling Cisco UCS's service:

1. Costs.
2. Benefits to the entire organization.
3. Flexibility.
4. Risk.

Given the increasing sophistication that enterprises have regarding ROI analyses related to IT investments, Forrester's TEI methodology serves the purpose of providing a complete picture of the total economic impact of purchase decisions. Please see Appendix B for additional information on the TEI methodology.

Analysis

Interview Highlights

A total of five interviews were conducted for this study, involving representatives from the following companies (Cisco customers based in the US):

1. A provider of critical communication and compliance solutions. The firm has about 150 employees and 3,500 customers. The firm's innovation and growth has resulted in a number of industry recognitions.
2. A regional medical center that has 400 beds and serves nearly 500,000 outpatients annually.
3. An energy management and conservation organization that was formed in 2008. As a midstage startup, the organization's IT department has to cater to a constantly changing and expanding business environment.
4. A university that serves a growing adult education business online and on campus. The IT department supports 5,000 employees and 55,000 students.
5. An Ivy League university with a large undergraduate and graduate population.

The five organizations interviewed are operating in different industries, but they all shared similar benefit gains. After deployment of UCS, these organizations experienced capital and operational savings. The interviews revealed the following:

- One of the primary reasons they chose Cisco UCS versus the other vendors that they were evaluating was UCS's memory technology. These firms were memory-bound and not CPU-bound.
- The UCS density and the ability to rack more within the existing space was another selling point. Customers mentioned that for computing power comparable with their legacy environments, they were able to reduce their power and cooling costs and data center storage space.
- Organizations interviewed needed to allocate resources to work on new projects that enable them to innovate. As their IT dollars shrank or remained the same, they looked into various ways to reduce time and effort allocated to ongoing management tasks so IT resources can be allocated to new projects and initiatives. As a result, UCS management architecture became another selling point. One of the customers mentioned that with alternative equipments, each chassis is its own entity that must be managed independently. However, with UCS, the system can grow to 20 chassis but continues to be managed as single entity. This also simplifies any hardware changes that need to take place. The management controller provides a simple way to switch equipment. These are significant time savings considerations that customers made while they were evaluating the solution. In addition, the customers were able to manage the system remotely. This was another selling point for organizations that were managing multiple locations. During a time of emergency, the IT administrators had the ability to quickly address and resolve issues remotely without being required to physically travel to the site.
- Companies combined hypervisor-based virtualization initiatives using products such as VMware and Hyper-V with UCS implementation. These customers earned greater ongoing IT administrative management savings and end user productivity. For the purpose of this study, we elected to remove the incremental gain from software-

based virtualization from our analysis and to simply illustrate the value of UCS. Note that UCS uses the term “service profile” to refer to its ability to virtualize attributes of the actual physical blade servers themselves.

- Customers interviewed purchased Cisco UCS through value-added resellers or Cisco direct sales. Customers that purchased through Cisco direct sales expressed great satisfaction with their sales team. Cisco sales engineers delivered all proof-of-concepts sessions in both selling scenarios. When the equipment arrived at the customers’ site, a Cisco professional services consultant was on-premises for five days to provide supervisory support during implementation.
- Customers interviewed all agreed that from the time Cisco UCS equipment arrived at their docks until it was ready to receive VMs were approximately a week. These customers believed this type of architectural simplification contributed to the time saving required to get equipment ready for new and existing projects. In addition, they believed the time it takes to complete new projects is also positively impacted because they are saving setup time during the initial stage of project rollout. Ultimately, these time saving efforts impact the time-to-market associated with the new initiatives and could lead to future business benefits.
- Customers knew Cisco’s networking and storage connectivity capability, but they were unfamiliar with its UCS offering. During initial phases of discovery, all interviewed customers were questioning Cisco’s future as a player in this space. One customer said, “I was questioning if Cisco UCS will be there three years from now?” Those concerns were put to rest during the proof-of-concept phase when the customers had the ability to review UCS’s capability and architecture.
- All the customers interviewed had expanded their UCS footprint since the initial deployment. These organizations used additional dollars that were either allocated to hardware purchases for new initiatives or assigned to hardware refresh budgets for existing equipments.

Composite Organization

Based on the interviews with the five existing customers provided by Cisco, Forrester constructed a TEI framework, a composite company, and an associated ROI analysis that illustrates the areas financially affected. The composite organization that Forrester synthesized from these results represents a medium-size US-based organization with 1,200 employees and 5,000 customers. Prior to implementing Cisco UCS, the organization had virtualized its environment. When the IT team decided to purchase Cisco UCS, they tied their purchases to their refresh schedule to maximize the investment and reduce effort to migrate to UCS. The investment in UCS included the equipment necessary to meet the refresh demand and the units required for upcoming projects; as well as, training for data center personnel.

Framework Assumptions

Table 2 provides the model assumptions that Forrester used in this analysis.

Table 2

Model Assumptions

Ref.	Metric	Calculation	Value
A1	Hours per week		40
A2	Weeks per year		52
A3	Hours per year (M-F, 9-5)		2,080
A4	Annual fully loaded salary of project manager		\$180,000
A5	Hourly	(A4/A3)	\$87

Source: Forrester Research, Inc.

The discount rate used in the PV and NPV calculations is 10%, and time horizon used for the financial modeling is three years. Organizations typically use discount rates between 8% and 16% based on their current environment, alternative investment options and perceived risk. Readers are urged to consult with their respective company's finance department to determine the most appropriate discount rate to use within their own organizations.

Costs

This section describes and lists the costs related to planning, implementation, and training of UCS for the composite organization over a three-year period. The costs associated with deployment and management of UCS corresponds to the composite organization. Cost assumptions are based on aggregated findings from the customers interviewed for the TEI study. All costs are based on list price and do not include any negotiated discounts. The following cost model can serve as a framework for other organizations.

UCS Hardware, License, and Maintenance Fees

This category includes license and maintenance costs to buy, deploy and manage Cisco UCS and represents 80% of the overall investment. Organization interviewed all split their investment into two categories. All interviewees agreed that they have timed their investment in UCS with their plan to refresh number of hardware within their data center. They also mentioned they have made at least one subsequent purchase to use UCS for new and upcoming projects. Table 3 illustrates the calculation.

Table 3

UCS Hardware, License, and Maintenance Fees

Ref.	Metric	Calculation	Initial	Year 1	Year 2	Year 3
B1	First investment		\$150,000			
B2	Second investment			\$200,000		
B3	Ongoing support (SMARTNet)			\$21,000	\$21,000	\$21,000
Bt	UCS hardware, license, and maintenance fees (Enterprise list price)	B1+B2+B3	\$150,000	\$221,000	\$21,000	\$21,000

Source: Forrester Research, Inc.

UCS Port and Switch Costs

The next component of cost is the IP and Fibre Channel ports and their related cabling costs. This category represents 5% of the overall investment. For the composite organization, we estimate eight IP and FC network ports. Unlike traditional servers, server ports are built into UCS design; therefore, there are no additional costs for server ports.

Based on UCS architecture, the composite organization needs eight IP network ports and eight FC network ports. These ports approximately cost \$208 and \$900, respectively. In addition, a \$50 charge per port is required for cabling. To complete the equation, we are also estimating the cost to add uplink module from the UCS Fabric Interconnect to the enterprise fabric. This model included one set of these per Fabric Interconnect module. These uplinks are shared across all the blades in the UCS instance. The interviewed organizations all had A and B uplinks for redundancy (see rows C7 to C10 in Table 4). Table 4 presents the results.

Table 4
UCS Port and Switch Costs

Ref.	Metric	Calculation	Initial
C1	IP network port		8
C2	Northbound switch cost per IP network port		\$208
C3	FC network port		8
C4	Northbound switch cost per FC network port		\$900
C5	Cable cost estimate per port		\$50
C6	Server port cost	Built into UCS design	\$0
C7	4-port 10 GE/4-port 4Gb FC/Expansion module/UCS 6100 Series		\$2,800
C8	4 Gbps Fibre Channel-SW SFP, LC		\$69
C9	10GBASE-SR SFP Module		\$797
C10	Number of UCS 6120 Fabric Interconnects		2
Ct	UCS port and switch costs	$[C1*(C2+C5+C6)]+[C3*(C4+C5+C6)]+[(C7+4*C8+4*C9)*C10]$	\$22,192

Source: Forrester Research, Inc.

Implementation Costs

The implementation cost includes all the internal resources necessary to accomplish a successful implementation and represents 10% of the overall investment. Our interviewed organizations highlighted that a number of roles within the IT organization allocated a portion of their time during the two months to discovery, design, testing, and implementation. The organization involved four employees during this two-month phase: a project manager with an average fully loaded salary of \$180,000, a VMware engineer and a storage engineer with a fully loaded salary of \$150,000 each, and a system administrator with a fully loaded salary of \$120,000. The program manager allocated 30% of his time during the two-month phase, the VMware engineer spent 50%, the storage engineer contributed 75%, and the system administrator spent 50% of his time. Table 5 illustrates the calculation.

Table 5

Implementation Costs

Ref.	Metric	Calculation	Initial
D1	Number of project managers		1
D2	Percent of project manager contribution		30%
D3	Fully loaded salary of project manager	For the two months of involvement	\$30,000
D4	Number of VMware engineers		1
D5	Percent of VMware engineer contribution		50%
D6	Number of storage engineers		1
D7	Percent of storage engineer contribution		75%
D8	Fully loaded salary of engineers	For the two months of involvement	\$25,000
D9	Number of system administrators		1
D10	Percent contribution		50%
D11	Fully loaded salary of system administrator	For the two months of involvement	\$20,000
Dt	Implementation costs	$(D1 * D2 * D3) + [(D4 * D5 + D6 * D7) * D8] + (D9 * D10 * D11)$	\$50,250

Source: Forrester Research, Inc.

Training Fees

Using Cisco Learning Credits program, all the organizations interviewed participated in a two-day course provided by a third-party training company. The event costs \$10,000, and an organization can bring up to 16 employees. This investment represents 2% of the overall investment. Table 6 shows the calculation.

Table 6

Training Fees

Ref.	Metric	Calculation	Initial
E1	Cost of Firefly training per company		\$10,000
Et	Training fees	E1	\$10,000

Source: Forrester Research, Inc.

Training Opportunity Costs

In addition to estimating the training fees paid, we are also calculating the opportunity costs to attend a two-day training course. We assume an average fully loaded hourly rate of \$67 per member attending this two-day event. This cost represents 1% of the overall investment. Table 7 presents this equation.

Table 7

Training Opportunity Costs

Ref.	Metric	Calculation	Initial
F1	Number of people		3
F2	Average fully loaded hourly rate		\$67
F3	Hours allocated	Two 8-hour days	16
Ft	Training opportunity costs	$F1 * F2 * F3$	\$3,216

Source: Forrester Research, Inc.

Professional Services Fees

A member of the Cisco professional services team provided on-site support for the interviewed organizations. The individual spent a week in a supervisory role to address issues or answer questions while the interviewed organizations were deploying UCS. While not required, having the Cisco services support on site in a supervisory role for the implementation process was beneficial. This cost represents 2% of the overall investment. Table 8 illustrates this calculation.

Table 8

Professional Services Fees

Ref.	Metric	Calculation	Initial
G1	Number of people		1
G2	Cost per day		\$2,000
G3	Number of days		5
Gt	Professional services fees	$G1 * G2 * G3$	\$10,000

Source: Forrester Research, Inc.

Total Costs

Table 9 summarizes the composite organization's costs associated with its implementation of Cisco UCS. Figure 5 illustrates the breakdown of costs.

Table 9

Total Costs — Non-Risk-Adjusted

Costs	Initial	Year 1	Year 2	Year 3	Total	PV
UCS hardware, license, and maintenance fees	(\$150,000)	(\$221,000)	(\$21,000)	(\$21,000)	(\$413,000)	(\$384,042)
UCS port and switch costs	(\$22,192)				(\$22,192)	(\$22,192)
Implementation costs	(\$50,250)				(\$50,250)	(\$50,250)
Training fees	(\$10,000)				(\$10,000)	(\$10,000)
Training opportunity costs	(\$3,216)				(\$3,216)	(\$3,216)
Professional services fees	(\$10,000)				(\$10,000)	(\$10,000)
Total costs	(\$245,658)	(\$221,000)	(\$21,000)	(\$21,000)	(\$508,658)	(\$479,700)

Source: Forrester Research, Inc.

Figure 5

Total Costs Breakdown — Non-Risk-Adjusted

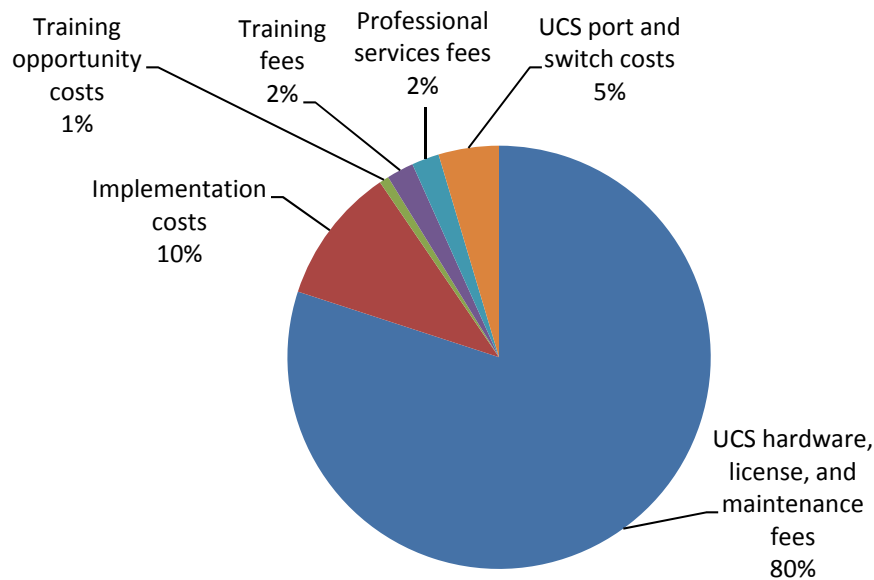

Source: Forrester Research, Inc.

Benefits

The benefits that we had sufficient data to quantify financially are capital and operational savings. These benefits includes the savings realized when the interviewed organizations replaced their existing hardware that needed to be refreshed as well as the hardware purchased for new projects.

The benefit that is financially quantifiable and mentioned by interviewees, but for which we were unable to obtain sufficient data to include in this analysis is - the improvement in time-to-market of application that IT delivers to the business units, which allows end users to become more efficient or produce products or services that improves the bottom line.

Reduction In Ongoing Administrative Effort

This represents the time and effort reduced when managing the data center. This savings contributes 22% to the overall benefit for the composite organization, a 50% time saving for a \$126,000 annual savings. In the Cost section of this study, we estimated the administrative effort to perform discovery, testing, and provisioning when setting up Cisco UCS. This section measures the reduction in ongoing management time between the Cisco UCS and the prior environment.

Organizations interviewed were able to reduce 50% of the time allocated to repetitive management tasks after implementing UCS. These organizations were able to shift their resources' time to new and innovative projects. While IT budgets often shrunk or remained the same, the demand for IT resources simply increased to meet the challenges they needed to simplify their organization. Some of the organizations interviewed also virtualized their previously

physical environment and they realized even greater IT ongoing administrative savings. In this section, we assume that the composite organization had virtualized prior to migration of Cisco UCS, and we are only measuring the benefit associated with the implementation of UCS. Readers should be aware that there may be additional savings and economies available in their specific situations, as indicated above.

We estimate that the composite organization had three IT staffs with an average fully loaded salary of \$140,000. These individuals on average spent 60% of their time on installation, management, and provisioning of their prior hardware environment. Migrating to UCS allowed them to decrease 50% of the group's allocated time on tasks as previously stated. We calculate the annual savings of \$126,000 ($3 * \$140,000 * 60% * 50%$) in Table 10.

Table 10
Reduction In Ongoing Administrative Effort

Ref.	Metric	Calculation	Per period
M1	Number of IT support staff		3
M2	Average annual fully loaded salary		\$140,000
M3	Average time allocated annually to install, manage, provision hardware		60%
M4	Percent effort saved		50%
Mt	Reduction in ongoing administrative effort	$M1 * M2 * M3 * M4$	\$126,000

Source: Forrester Research, Inc.

Network Port and Switches Cost Reduction

This cost represents 53% of the overall the savings for the composite organizations. Versus traditional server networking implementation, UCS saves 400 IP port and 400 FC ports that equates to \$823,200. The interviewed organizations all agreed that UCS's simplified structure eliminates the need to purchase and maintain a large number of IP network ports and FC network ports as well as their related cabling costs that would have been necessary with traditional server implementation.

In this section, we estimate the cost avoided when our interviewees eliminated the number of ports and switches required to connect into the data center. In the Cost portion of the study, we estimated that the composite organization will be installing eight IP networking port and eight FC networking port to connect UCS. It is important to highlight the magnitude of savings for the composite organization. We are estimating that as a result of implementing UCS, the composite organization is reducing 400 IP networking port and 400 FC networking port as well as the associated cost of cabling.

We do not calculate the IT administrative effort associated with the setup and monitoring of these units. Our interviewed organizations agreed that the large numbers of ports and switches often lead to human-made error. As a

result, troubleshooting became a challenging issue, as they had a large of number of ports and switches to test. In addition, we learned that the simplified port architecture also improved the time needed to make any hardware changes. For example, they are not managing multiple switches and ports when connecting into the data center.

To estimate this benefit, we estimate that the composite organization is spending \$208 per IP network port and \$900 per FC network port. We are also assuming a \$50 cost cabling per port and \$850 average server port cost. Table 11 represents the total one-time savings ($400 * [\$208 + \$50 + 0] + 400 * [\$900 + \$50 + \$850]$).

Table 11
Network Port and Switches Cost Reduction

Ref.	Metric	Calculation	Year 1
K1	Number of IP network ports		400
K2	Northbound switch cost per IP network port		\$208
k3	FC network port		400
K4	Northbound switch cost per FC network port		\$900
K5	Cable cost estimate per port		\$50
K6	Average server IP port cost (LAN on Motherboard)		\$0
K7	Average server FC port cost		\$850
Kt	Network port and switches cost reduction	$[K1 * (K2 + K5 + K6)] + [K3 * (K4 + K5 + K7)]$	\$823,200

Source: Forrester Research, Inc.

Refresh Cost Avoidance

This cost represents 14% of the overall benefits. This portion of the investment made in UCS was allocated to refresh of the fully depreciated hardware. All of the customers interviewed explained that they had timed their purchasing decision of Cisco UCS with their hardware refresh cycle. As a result, these organizations shifted their investment budgeted to replace the traditional hardware with Cisco UCS. We have previously estimated the impact this shift had on power and cooling, data center space savings, and network and port reduction. We assume that the composite organization was planning to replace twelve servers in Year 1, ten servers in Year 2, and six servers in Year 3. At a cost of \$8,000 per server, we calculated the following savings: \$96,000 in Year 1, \$80,000 in Year 2, and \$48,000 in Year 3. Table 12 illustrates the result.

Table 12

Refresh Cost Avoidance

Ref.	Metric	Calculation	Year 1	Year 2	Year 3
L1	Number of servers refreshed		12	10	6
L2	Cost per server		\$8,000		
Lt	Refresh cost avoidance	L1*L2	\$96,000	\$80,000	\$48,000

Source: Forrester Research, Inc.

Power and Cooling Cost Savings

This section represents 3% of the overall benefits for the composite organization. This equates to an annual OpEx savings of 30% for interviewed organizations for the same amount of compute power, or \$16,000 annually on a \$53,300 power bill each year. This is calculated by looking at the difference in power and cooling costs between the UCS environment and the prior traditional server and networking structure. Table 13 represents this calculation.

Table 13

Power and Cooling Cost Savings

Ref.	Metric	Calculation	Per period
I1	Power and cooling annual savings		\$16,000
It	Power and cooling cost savings	I1	\$16,000

Source: Forrester Research, Inc.

Electrical Circuit Cost Avoidance

This category represents 3% of the overall benefits for the composite organization and equals a savings of \$48,000 vs. continuing a current path implementation. Prior to UCS, our interviewees estimated the cost to add electrical circuits to accommodate the power demand when planning to purchase the alternative hardware to achieve the same computing power. UCS implementation eliminated this need.

We assumed that the composite organization eliminated the need to add four 30 AMP circuits at a monthly cost of \$1,000 per circuit. For the composite organization, this category equates to a one-time savings of \$48,000 (4*\$1,000*12). Table 14 represents the calculation.

Table 14

Electrical Circuit Cost Avoidance

Ref.	Metric	Calculation	Year 1
H1	Number of 30 AMP circuit reduced at the hosted data center	30 AMP circuit	4
H2	Monthly cost per circuit		\$1,000
H3	Number of months per year		12
Ht	Electrical circuit cost avoidance	$H1*H2*H3$	\$48,000

Source: Forrester Research, Inc.

Data Center Space Cost Savings

This category represents 3% of the overall savings which equates to net reduction of 4 racks and an annual OpEx savings of \$16,000 for data center real estate cost. Our interviewed organizations reduced the total amount of physical hardware while they increased their computing power. Retaining the same data center space while increasing computing power and reducing power and cooling costs was an important benefit to our interviewees. It eliminated the need to consider expansion to another location on-premises or an outside location. Both options would have added setup and management costs and would have increased project cost. The cost avoidance savings of a new data center was not included in this analysis. Only the actual space savings associated with implementing a UCS solution were included. Allowing the organization to refresh its existing hardware, simplify its environment, and reduce potential real estate expenses were significant benefits.

After implementing UCS, we estimated that the composite organization eliminated four racks. A rack takes about four square feet of space². With an average cost per square footage of \$1,000, we calculate that the composite organization is saving \$16,000 annually ($4*4*\$1,000$). Table 15 represents this calculation.

Table 15

Data Center Space Cost Savings

Ref.	Metric	Calculation	Per period
J1	Reduction in the number of racks		4
J2	Average square footage per server		4
J3	Average annual cost per square footage		\$1,000
Jt	Data center space cost savings	$J1*J2*J3$	\$16,000

Source: Forrester Research, Inc.

End User Productivity Savings

This saving contributes 2% to the overall benefit. This cost represents an improvement in end user productivity when the number of planned and unplanned downtimes was reduced. For the sample customers we interviewed, we noticed that some customers initially virtualized their environment and then refreshed their outdated hardware. The second group of customers combined the virtualization and UCS migration into one large IT project. From the feedback received, we learned that virtualization was one of the primary methods that allowed the organizations interviewed to reduce the impact of downtime on end users. However, for customers that virtualized first without upgrading their hardware, we learned that hardware failure continued to play a role in causing additional downtime, which was mitigated for these interviewees when they adopted UCS.

By replacing the outdated hardware, these organizations were able to further improve users' productivity. Again, readers should note that we are aiming to measure the impact of UCS in an organization. We have taken great care to separate the effect of virtualization and its benefits.

Many organizations interviewed also stated that by using UCS, they have been able to reduce the time-to-completion (production) of their applications for their business units, allowing end users to have access to applications faster. We have not been able to quantify the impact of this time-to-market improvement for end users. None of the interviewed organizations were tracking improvement in time-to-market of application that IT delivers to the business units, which allows end users to become more efficient or produce products or services that improves the bottom line, but they did acknowledge that there was a definite benefit.

To calculate the End User Productivity benefit, we are estimating that the composite organization had 1,200 workers. We assume that only 20% of the users are affected by hardware downtime of about 2 hours annually. We estimate that with an average fully loaded hourly rate of \$48, the composite organization could capture 50% of the benefit. Table 16 represents this calculation.

Table 16

End User Productivity Savings

Ref.	Metric	Calculation	Per period
N1	Number of workers		1,200
N2	Subset of users		20%
N3	Average fully loaded hourly rate		\$48
N4	Number of hours (saved) annually (loss of access)		2
N5	Percent captured		50%
Nt	End user productivity savings	$N1*N2*N3*N4*N5$	\$11,520

Source: Forrester Research, Inc.

Total Benefits

The total benefits for the composite organization are \$1,403,024 (see Table 17). Figure 6 illustrates benefit breakdown.

Table 17

Total Benefits — Non-Risk-Adjusted

Benefits	Year 1	Year 2	Year 3	Total	PV
Reduction in ongoing administrative effort	\$126,000	\$126,000	\$126,000	\$378,000	\$313,343
Network port and switches cost reduction	\$823,200			\$823,200	\$748,364
Refresh cost avoidance	\$96,000	\$80,000	\$48,000	\$224,000	\$189,452
Power and cooling cost savings	\$16,000	\$16,000	\$16,000	\$48,000	\$39,790
Electrical circuit cost avoidance	\$48,000			\$48,000	\$43,636
Data center space cost savings	\$16,000	\$16,000	\$16,000	\$48,000	\$39,790
End user productivity savings	\$11,520	\$11,520	\$11,520	\$34,560	\$28,649
Total benefits	\$1,136,720	\$249,520	\$217,520	\$1,603,760	\$1,403,024

Source: Forrester Research, Inc.

Figure 6

Total Benefits Breakdown — Non-Risk-Adjusted

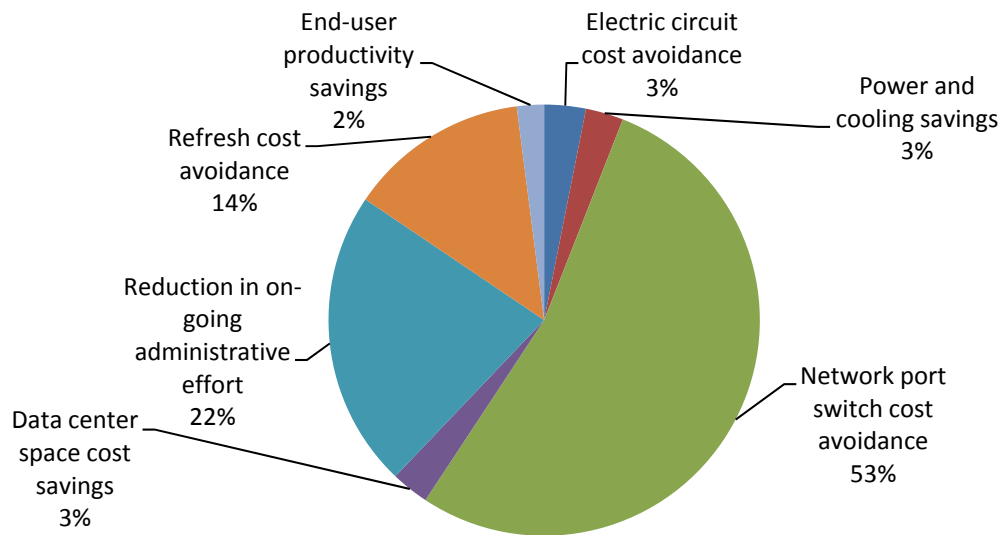

Source: Forrester Research, Inc.

Flexibility

Flexibility, as defined by TEI, represents an investment in additional capacity or capability that could be turned into business benefit for some future additional investment. This provides an organization with the “right” or the ability to engage in future initiatives but not the obligation to do so. There are multiple scenarios in which a customer might choose to implement Cisco UCS and later realize additional uses and business opportunities. Flexibility would also be quantified when evaluated as part of a specific project (described in more detail in Appendix B).

As the enabler, IT is in the business of serving its business users. The ability to take product and services to market faster, better, and cheaper and offer the agility needed for business to deliver benefit is the key to this implementation. The customers interviewed have invested in UCS can increase the number of chassis, blades, or rack quickly and efficiently to support existing and new projects. The created framework allows the organizations interviewed to expand and adjust their environment as necessary to meet business demand.

Risk

Forrester defines two types of risk associated with this analysis: implementation risk and impact risk. “Implementation risk” is the risk that a proposed investment in Cisco UCS may deviate from the original or expected requirements, resulting in higher costs than anticipated. “Impact risk” refers to the risk that the business or technology needs of the organization may not be met by the investment in Cisco UCS, resulting in lower overall total benefits. The greater the uncertainty, the wider the potential range of outcomes for cost and benefit estimates.

Quantitatively capturing investment and impact risk, by directly adjusting the financial estimates results in more meaningful and accurate estimates and a more accurate projection of the ROI. In general, risks affect costs by raising the original estimates, and they affect benefits by reducing the original estimates. The risk-adjusted numbers should be taken as “realistic” expectations, as they represent the expected values considering risk.

The following implementation risks that affect costs and benefits are identified as part of this analysis:

- The implementation costs will vary with the complexity of each user’s environment, the number of applications, and the degree of integration with other systems.
- Port and switch costs may vary depending on the architecture and the number of hardware being deployed.
- Implementation costs could vary depending on the user’s skills and plan.
- Customers’ benefits could vary depending on their infrastructure.

Table 18 shows the values used to adjust for risk and uncertainty in the cost and benefit estimates. The TEI model uses a triangular distribution method to calculate risk-adjusted values. To construct the distribution, it is necessary to first estimate the low, most likely, and high values that could occur within the current environment. The risk-adjusted value is the mean of the distribution of those points. Readers are urged to apply their own risk ranges based on their own degree of confidence in the cost and benefit estimates.

Table 18

Cost And Benefit Risk Adjustments

Costs	Low	Most likely	High	Mean
UCS port and switch costs (medium risk level)	100%	100%	115%	105%
All other cost categories (low risk level)	98%	100%	105%	101%
Benefits	Low	Most likely	High	Mean
Network port and switches cost reduction (medium risk level)	80%	100%	103%	94%
All other benefits categories (low risk level)	90%	100%	105%	98%

Source: Forrester Research, Inc.

Financial Summary

The financial results calculated in the Costs and Benefits sections can be used to determine the ROI, NPV, and payback period for the organization's investment in UCS. These are shown in Table 19 below.

Table 19

Cash Flow — Non-Risk-Adjusted

Categories	Initial	Year 1	Year 2	Year 3	Total	PV
Costs	(\$245,658)	(\$221,000)	(\$21,000)	(\$21,000)	(\$508,658)	(\$479,700)
Benefits	0	\$1,376,720	\$249,520	\$217,520	\$1,603,760	\$1,403,024
Net benefits	(\$245,658)	\$915,720	\$228,520	\$196,520	\$1,095,102	\$923,324
ROI	192%					
Payback period	3 months					

Source: Forrester Research, Inc.

Table 20 below shows the risk-adjusted ROI, NPV, and payback period values. These values are determined by applying the risk-adjustment values from Table 18 in the Risk section to the cost and benefits numbers in Tables 9 and 17.

Table 20

Cash Flow — Risk-Adjusted

Categories	Initial	Year 1	Year 2	Year 3	Total	PV
Costs	(\$249,002)	(\$223,210)	(\$21,210)	(\$21,210)	(\$514,632)	(\$485,385)
Benefits		\$1,081,058	\$244,530	\$213,170	\$1,538,757	\$1,345,029
Net benefits	(\$249,002)	\$857,848	\$223,320	\$191,960	\$1,024,125	\$859,644
ROI	177%					
Payback period	4 months					

Source: Forrester Research, Inc.

Cisco Unified Computing System: Overview

Cisco UCS unites computing, network, storage access, and virtualization into a cohesive system designed to reduce total cost of ownership (TCO) and increase business agility. The Cisco UCS is built from the following components:

- **Cisco UCS 6100 Series Fabric Interconnects:** line-rate, low-latency, lossless interconnect switches.
- **Cisco UCS 5100 Series Blade Server Chassis:** support for up to eight blade servers and up to two Fabric Extenders in a 6-rack unit (RU) enclosure.
- **Cisco UCS 2100 Series Fabric Extenders:** two per 5100 Series blade chassis, provide unified fabric in the Blade Server Chassis, up to four 10 Gbps connections on each Fabric Extender.
- **Cisco UCS B-Series Blade Servers:** enhanced support for application demands, energy use, and virtualization.
- **Cisco UCS B-Series Network Adapters:** a range of adapters optimized for virtualization, compatibility with existing driver stacks, or efficient, high-performance Ethernet.
- **Cisco UCS C-Series Rack-Mount Servers:** the benefits of the UCS in a rack-mount form factor.
- **Cisco UCS C-Series Network Adapters:** a choice of four types of PCI Express (PCIe) adapters.
- **Cisco UCS Manager:** centralized management capabilities that is integrated with, and comes with the UCS 6100 Series Fabric Interconnects.

Figures 7 and 8 illustrate the difference between traditional server and networking architecture and Cisco UCS design. The reader should note that adding more UCS blade servers does not necessarily require additional network switches.

Figure 7

Existing Traditional Server And Networking Architecture (6 rack server example – 30 total cables)

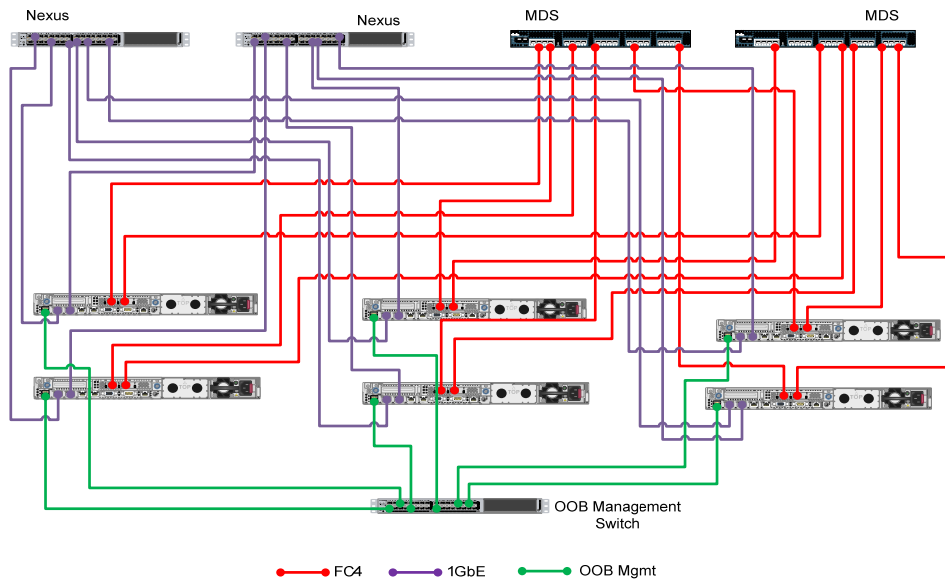

Source: Forrester Research, Inc.

Figure 8

Cisco UCS Architecture (24 blade server example – 32 total cables. Each additional 8 servers adds 4 cables to the total solution cable count)

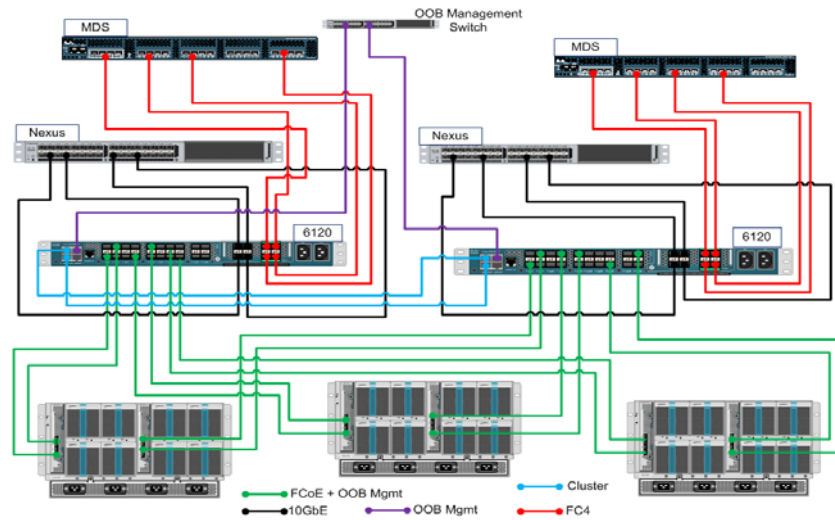

Source: Forrester Research, Inc.

Appendix A: Composite Organization Description

For this TEI study, Forrester has created a composite organization to illustrate the quantifiable costs and benefits of implementing Cisco UCS. Based on the interviews with the five existing customers provided by Cisco, Forrester constructed a TEI framework, a composite company, and an associated ROI analysis that illustrates the areas financially affected.

The composite company is intended to represent a medium-size US-based organization with 1,200 employees and 5,000 customers. Prior to implementing Cisco UCS, the organization had virtualized its environment. When the IT team decided to purchase Cisco UCS, it has aligned it with its refresh schedule to maximize the investment and reduce effort to migrate to UCS. The investment in UCS included the equipment necessary to meet the refresh demand and the unit required for upcoming projects.

In purchasing Cisco UCS, the composite company has the following objectives:

- Reduce the time and effort associated with the ongoing management of a data center to focus resources on new and innovative projects without the need to expand personnel.
- Reduce the power and cooling and data center footage while upgrading equipment and expanding to meet the memory requirement.

For the purpose of the analysis, Forrester assumes that the composite organization has virtualized prior to implementation of UCS.

Appendix B: Total Economic Impact™ Overview

Total Economic Impact is a methodology developed by Forrester Research that enhances a company's technology decision-making processes and assists vendors in communicating the value proposition of their products and services to clients. The TEI methodology helps companies demonstrate, justify, and realize the tangible value of IT initiatives to both senior management and other key business stakeholders.

The TEI methodology consists of four components to evaluate investment value: benefits, costs, risks, and flexibility.

Benefits

Benefits represent the value delivered to the user organization — IT and/or business units — by the proposed product or project. Often product or project justification exercises focus just on IT cost and cost reduction, leaving little room to analyze the effect of the technology on the entire organization. The TEI methodology and the resulting financial model place equal weight on the measure of benefits and the measure of costs, allowing for a full examination of the effect of the technology on the entire organization. Calculation of benefit estimates involves a clear dialogue with the user organization to understand the specific value that is created. In addition, Forrester also requires that there be a clear line of accountability established between the measurement and justification of benefit estimates after the project has been completed. This ensures that benefit estimates tie back directly to the bottom line.

Costs

Costs represent the investment necessary to capture the value, or benefits, of the proposed project. IT or the business units may incur costs in the form of fully burdened labor, subcontractors, or materials. Costs consider all the investments and expenses necessary to deliver the proposed value. In addition, the cost category within TEI captures any incremental costs over the existing environment for ongoing costs associated with the solution. All costs must be tied to the benefits that are created.

Risk

Risk measures the uncertainty of benefit and cost estimates contained within the investment. Uncertainty is measured in two ways: 1) the likelihood that the cost and benefit estimates will meet the original projections, and 2) the likelihood that the estimates will be measured and tracked over time. TEI applies a probability density function known as “triangular distribution” to the values entered. At minimum, three values are calculated to estimate the underlying range around each cost and benefit.

Flexibility

Within the TEI methodology, direct benefits represent one part of the investment value. While direct benefits can typically be the primary way to justify a project, Forrester believes that organizations should be able to measure the strategic value of an investment. Flexibility represents the value that can be obtained for some future additional investment building on top of the initial investment already made. For instance, an investment in an enterprise wide upgrade of an office productivity suite can potentially increase standardization (to increase efficiency) and reduce licensing costs. However, an embedded collaboration feature may translate to greater worker productivity if activated. The collaboration can only be used with additional investment in training at some future point in time. However, having the ability to capture that benefit has a present value that can be estimated. The flexibility component of TEI captures that value.

Appendix C: Glossary

Discount rate: The interest rate used in cash flow analysis to take into account the time value of money. Although the Federal Reserve Bank sets a discount rate, companies often set a discount rate based on their business and investment environment. Forrester assumes a yearly discount rate of 10% for this analysis. Organizations typically use discount rates between 8% and 16% based on their current environment. Readers are urged to consult their respective organization to determine the most appropriate discount rate to use in their own environment.

Net present value (NPV): The present or current value of (discounted) future net cash flows given an interest rate (the discount rate). A positive project NPV normally indicates that the investment should be made, unless other projects have higher NPVs.

Present value (PV): The present or current value of (discounted) cost and benefit estimates given at an interest rate (the discount rate). The PV of costs and benefits feed into the total net present value of cash flows.

Payback period: The breakeven point for an investment. The point in time at which cumulative benefits equal initial investment plus ongoing cost.

Return on investment (ROI): A measure of a project's expected return in percentage terms. ROI is calculated by dividing net benefits (benefits minus costs) by costs.

A Note On Cash Flow Tables

The following is a note on the cash flow tables used in this study (see the example table below). The initial investment column contains costs incurred at "time 0" or at the beginning of Year 1. Those costs are not discounted. All other cash flows in Years 1 through 3 are discounted using the discount rate (shown in Framework Assumptions section) at the end of the year. Present value (PV) calculations are calculated for each total cost and benefit estimate. Net present value (NPV) calculations are not calculated until the summary tables and are the sum of the initial investment and the discounted cash flows in each year.

Table [Example]

Example Table

Ref.	Category	Calculation	Initial cost	Year 1	Year 2	Year 3	Total

Source: Forrester Research, Inc.

Appendix D: Endnotes

¹ Forrester risk-adjusts the summary financial metrics to take into account the potential uncertainty of the cost and benefit estimates. For more information on Risk, please see page 21.

² Measuring rack footprint in this manner also is not reflective of the total rack footprint relative to data center space and equipment. This is a “rack based” allowance and not based on servers. This is the more appropriate measure of rack footprint and therefore savings. A more accurate number would be 28 sq feet per rack. This is documented by an US EPA Energy Star paper at :

http://www.energystar.gov/ia/partners/prod_development/downloads/Additional_FAQs_LightingCooling_Racks.pdf
- “ENERGY STAR Data Center Infrastructure Rating Development Frequently Asked Questions”